

拖輪系列產品

PULLER ATTACHMENT

HPZ-380 鏈目縫車專用型 FOR SPECIFIC FLAT BED CHAINSTITCH

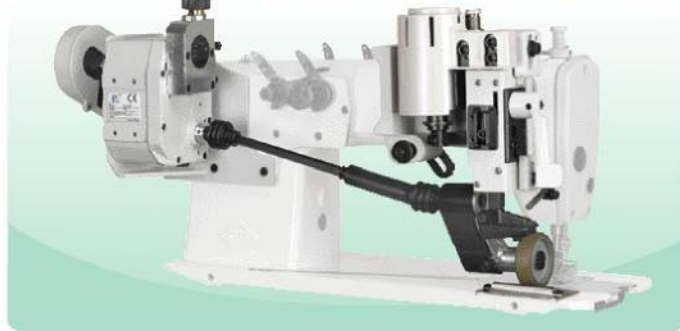

LxWxH: 615x374x238 mm N.W./G.W.: 8 / 10.5 kgs

- 縫製西裝褲專用，例如JUKI-380
For sewing career/dress pants, EX: JUKI-380
- 滾輪尺寸：直徑 55 mm，寬度 15 / 35 / 55 mm
Roller : Diameter 55 mm, Width 15 / 35 / 55 mm



HPF 腕型車用，皮帶式拖輪(極厚物型) FOR FEED-OFF-ARM (Belt puller for heavy to extremely heavy material)



LxWxH: 615x374x238 mm N.W./G.W.: 8 / 10.5 kgs

- 皮帶式拖輪，拉力特強。
Belt puller for powerful pulling strength.
- 皮帶寬帶：19 mm
Belt width: 19 mm

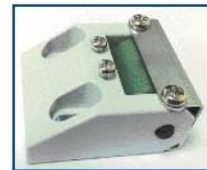

- 附下輪
With lower roller

HPT 單針、雙針車用，上下輪驅動(加強型) FOR SINGLE OR TWIN NEEDLE WITH UPPER AND LOWER ROLLER (Strengthened type)



LxWxH: 615x374x238 mm N.W./G.W.: 14 / 16.5 kgs

- 上下輪同時驅動，拉力特強，縫製順暢
Powerful upper and lower rollers drive
- 適合薄至極厚物，長距離車縫
For thin to heavy material
- 上輪：直徑 55 mm，寬度 15 / 35 / 50 mm
下輪：直徑 27 mm，寬度 60 mm
Upper roller : Diameter 55 mm, Width 15 / 35 / 50 mm
Lower roller : Diameter 27 mm, Width 60 mm

HPB 褲頭車用，上下輪驅動(厚物型) FOR SPECIFIC WAISTBAND WITH UPPER AND LOWER ROLLER (Heavy duty)



- 強力驅動，可防止針目大小不一
Powerful drivers making equal stitches.
- 適用於牛仔布等厚物
Suitable for heavy material, ex: jeans

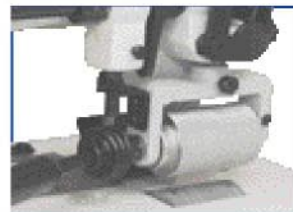

拖輪系列產品

PULLER ATTACHMENT

HPY 單針、雙針車用，上下輪驅動 FOR SINGLE OR TWIN NEEDLE WITH UPPER AND LOWER ROLLER

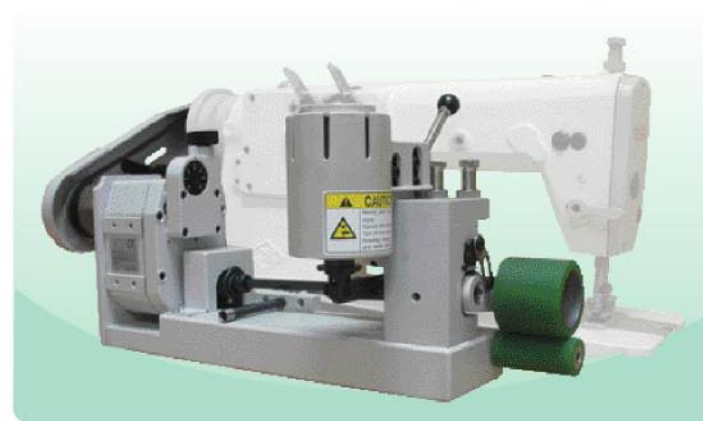

LxWxH: 615x374x238 mm N.W./G.W.: 9 / 10 kgs

- 上輪：直徑 55 mm，寬度 50 mm
下輪：直徑 27 mm，寬度 60 mm
- Upper roller: Diameter 55 mm, Width 50 mm
Lower roller: Diameter 27 mm, Width 60 mm

HPY-SP 前拉式(意大利麵專用) FRONT PULLER (For spaghetti sewing)



LxWxH: 615x374x238 mm N.W./G.W.: 9 / 10 kg

- 上輪：直徑 55 mm，寬度 50 mm
下輪：直徑 27 mm，寬度 60 mm
- Upper roller: Diameter 55 mm, Width 50 mm
Lower roller: Diameter 27 mm, Width 60 mm

HPY-C 飾縫車用 FOR COVERSTITCH



LxWxH: 615x374x238 mm N.W./G.W.: 9 / 10 kgs

- 上輪：直徑 55 mm，寬度 50 mm
下輪：直徑 27 mm，寬度 60 mm
- Upper roller: Diameter 55 mm, Width 50 mm
Lower roller: Diameter 27 mm, Width 60 mm